

Techna STRAIGHTENERS (WIRE & STRIP)

AS FX - Modular Straightener System with Partially Adjustable Rollers for High-Strength Process Materials

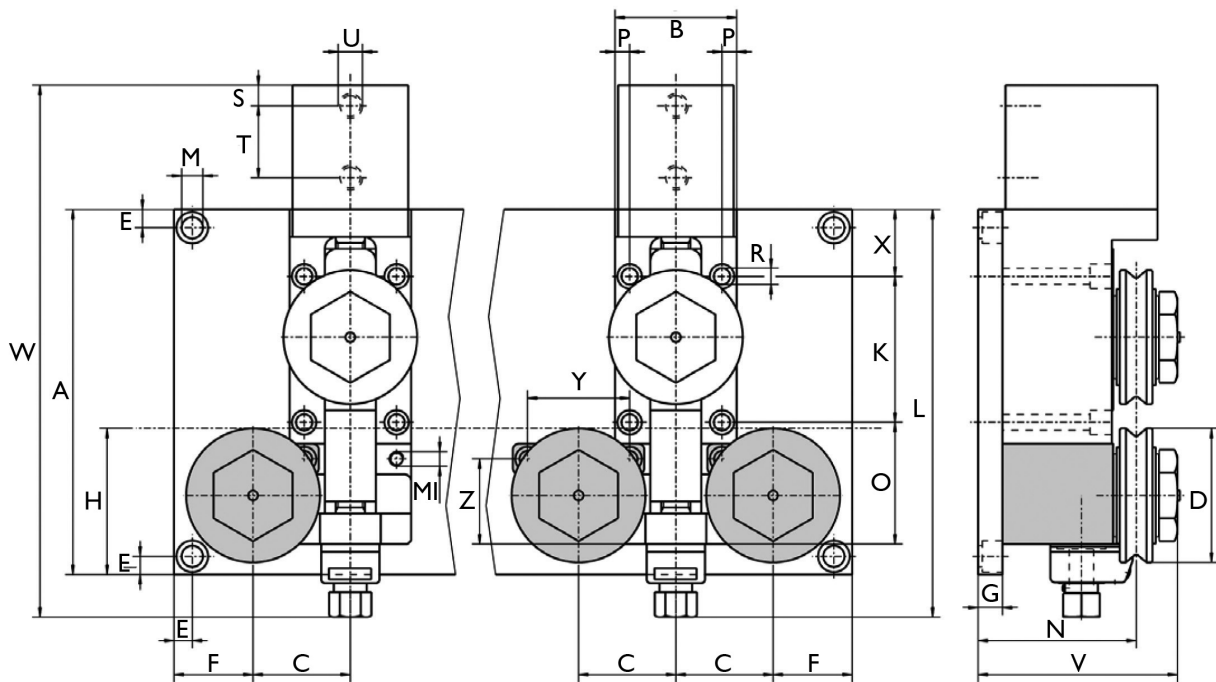

- For high-strength materials e.g. high-tensile steel for concrete reinforcement
- Modular system; add units to achieve the desired number of rolls
- Alternate rolls adjustable
- With positional counters to ensure repeatability



AS FX Series		Dimensions (mm)																						
Size Range (mm)	Order Ref.	A	B	C	D	E	F	G	H	K	L	M/M1	N	O	P	R	S	T	U	V	W	X	Y	Z
5 - 20	AS 1-20 FX	300	100	80	110	15	65	20	120	120	334	17/12	132	100	12	13	17	59	G 1/2"	168	436	55	84	70
20 - 40	AS 1-40 FX	570	200	160	200	30	140	30	210	100	579	26/16	174	105	15	17	25	70	G 1/2"	223	733	115	160	165

G 1/2" = Standard Hydraulic or Pneumatic Connector with 1/2" Whitworth thread